

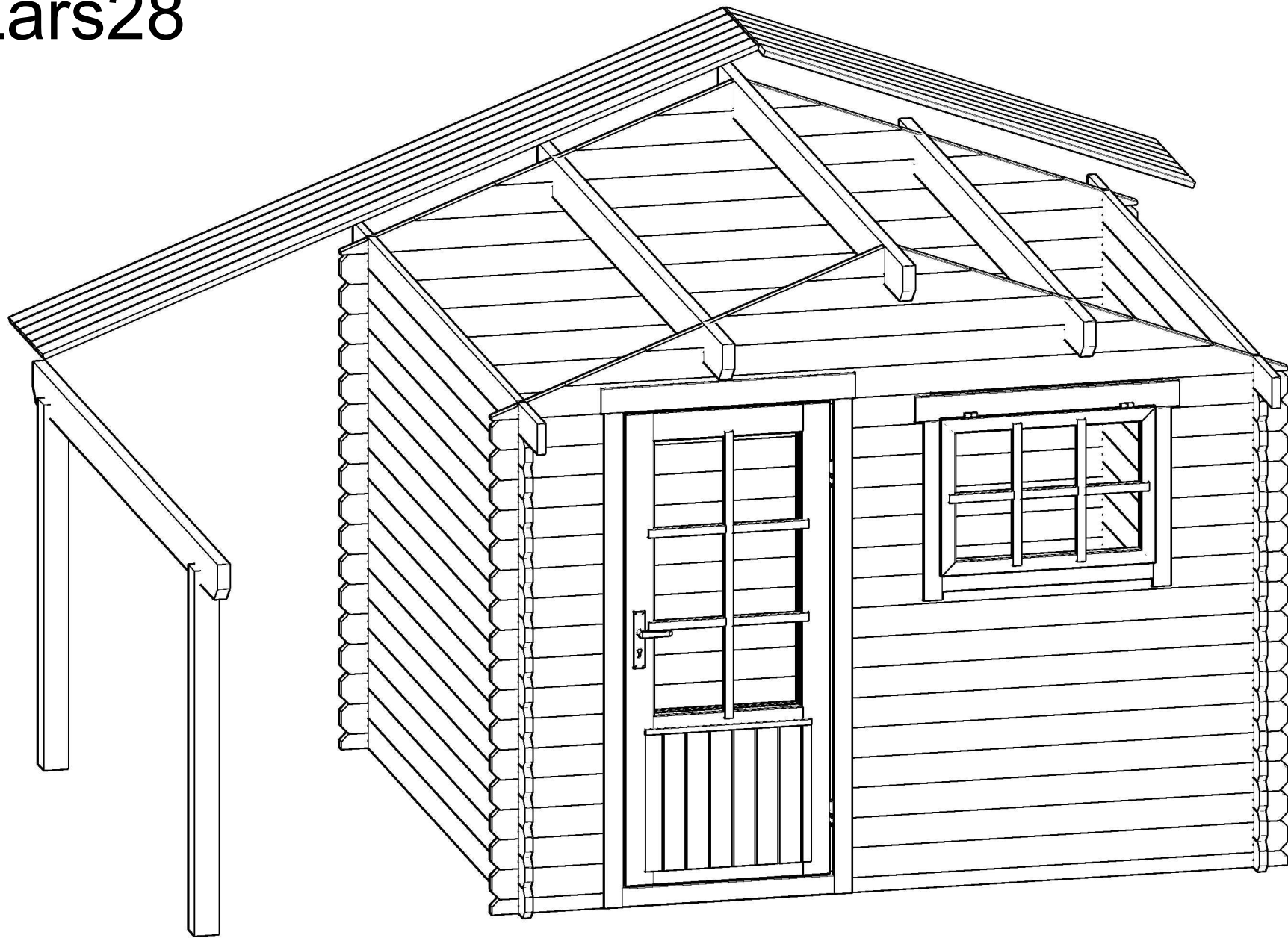

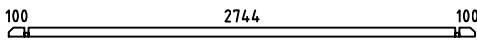







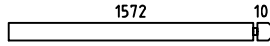

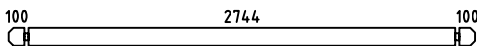
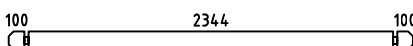
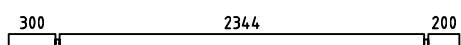
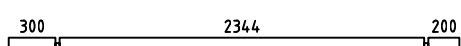
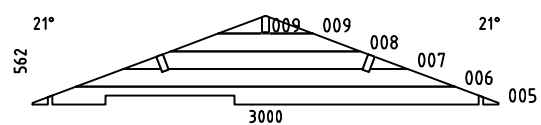
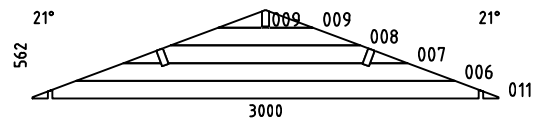
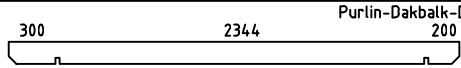
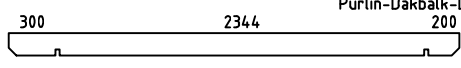
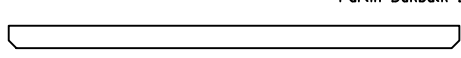
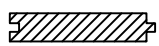

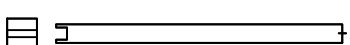
Lars28



Pos	Specification-Spezifikation-Specificatie	St.	Profile (mm)	Length (mm)
001		2	28x57	3000
002		22	28x114	470
003		10	28x114	1700
004		6	28x114	350
010		16	28x114	3000
012		32	28x114	2600
013		1	28x114	2900
014		1	28x114	2900
W1-1		1		
W2-1		1		
PR2		2	44x14,4	2900
PR3		1	44x14,4	2900
PR1		1	44x14,4	2900
DP-1	Roof board-Dachbrett-Dakplank 	33	88x18	2875
DP-2	Roof board-Dachbrett-Dakplank 	33	88x18	1730
	-POST 85x85 	2		1500
L-1	Eave Slat-Traufenleiste-Afdeklijst 	2	40x18	2900
L-2	Facia Board-Giebelblende-Gevelplank 	2	18x120	1770
L-3	Facia Board-Giebelblende-Gevelplank 	2	18x120	2915
L-4	Facia Slat-Giebelleiste-Gevellijst 	2	40x18	1770
L-5	Facia Slat-Giebelleiste-Gevellijst 	2	40x18	2915
	Adjustable foot-Stellfuß+Schrauben 5x40 4stück für Post 	2		
D1	Diamond 	2		

H = 1.200 m
 TOTAL: 6.43 m²

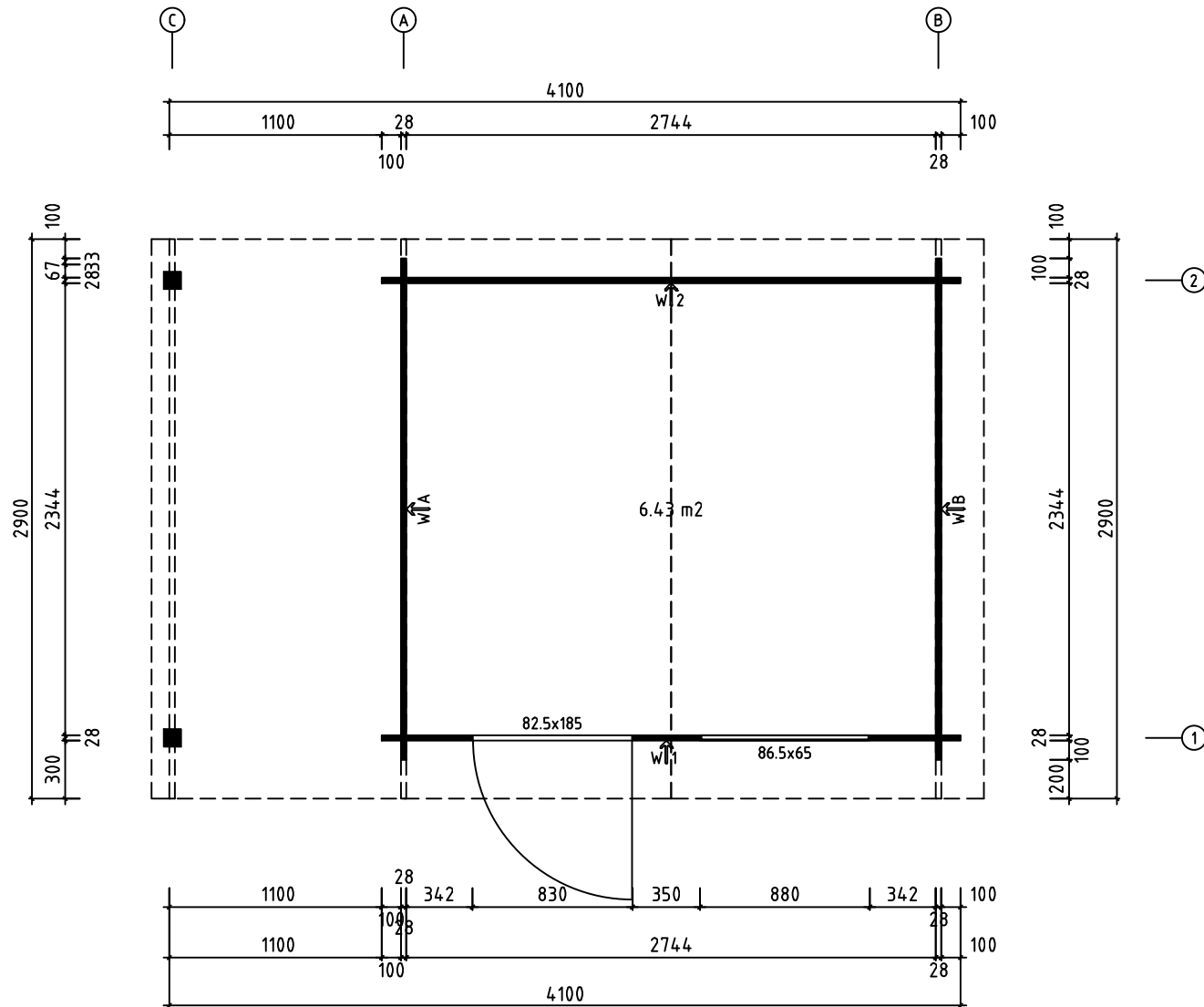

Model	Lars28	Page	
Client		Scale	1:25
Material	28x114	Date	10.11.2021
Company		File	Lars28.dwg

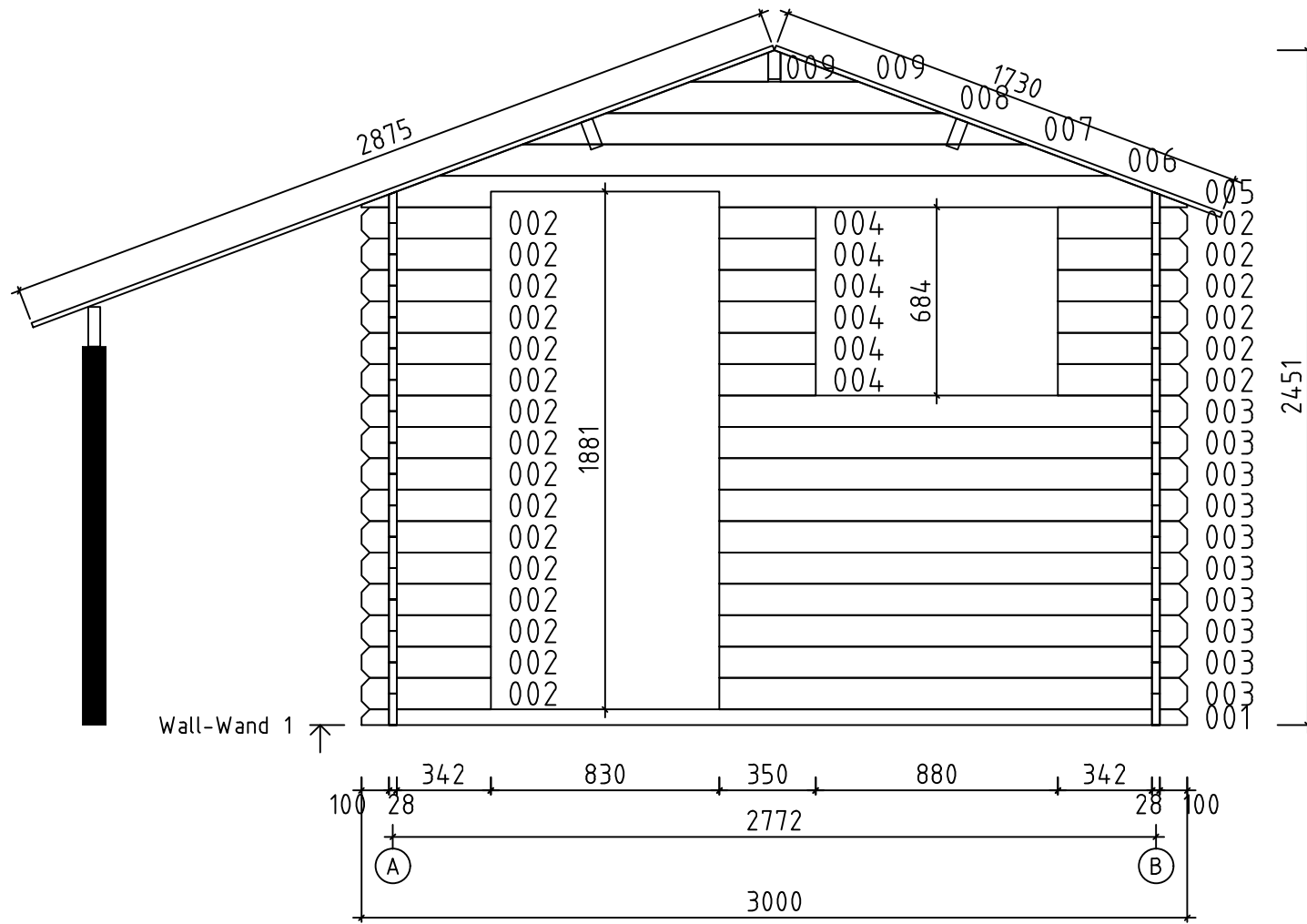

Model	Lars28	Page	5
Client		Scale	1:25
Material	2.8x11.4	Date	10.11.2021
Company		File	Lars28.dwg

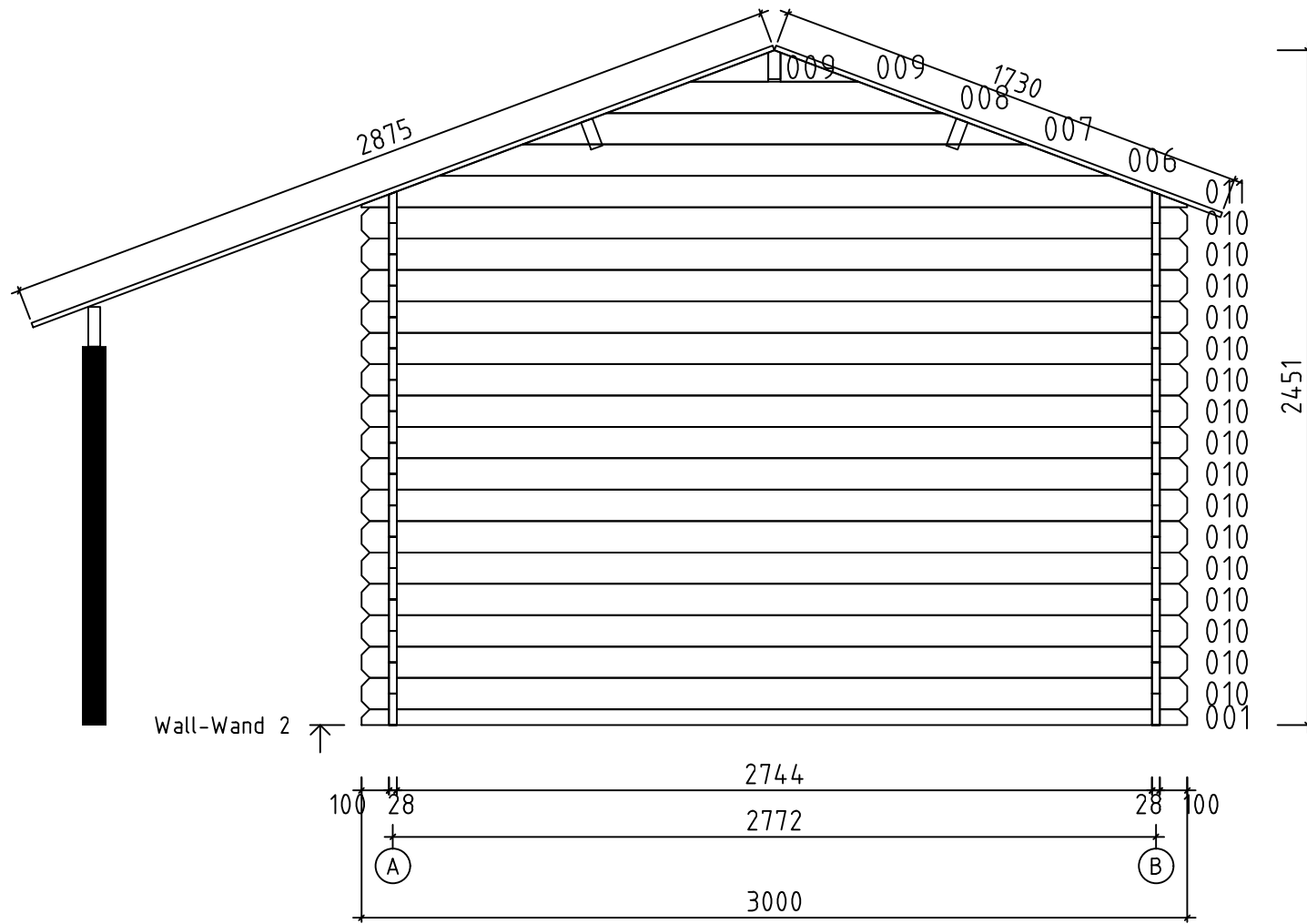

Model	Lars28	Page	6
Client		Scale	1:25
Material	2.8x11.4	Date	10.11.2021
Company		File	Lars28.dwg

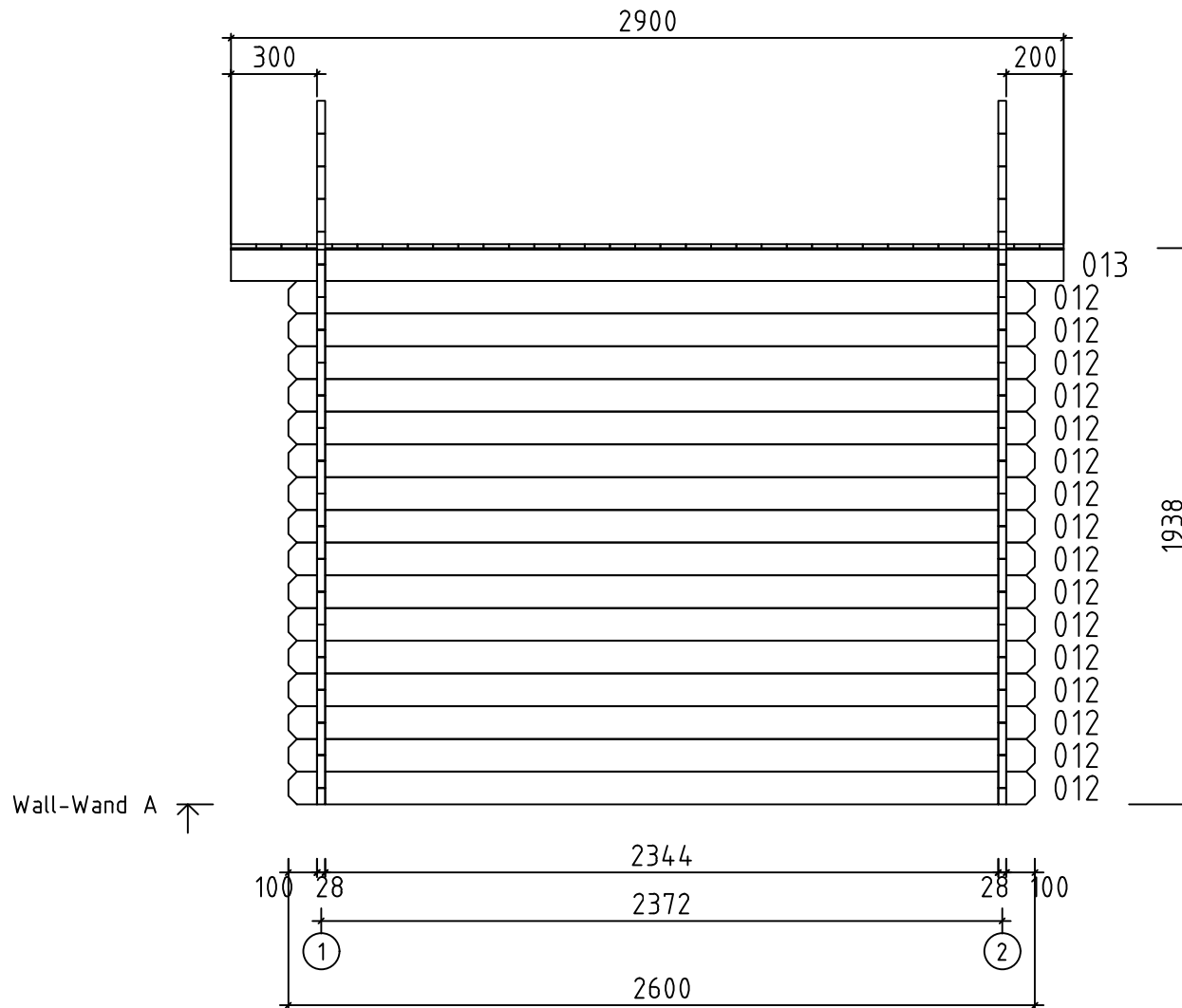

Model	Lars28	Page	2
Client		Scale	1:25
Material	2.8x11.4	Date	10.11.2021
Company		File	Lars28.dwg

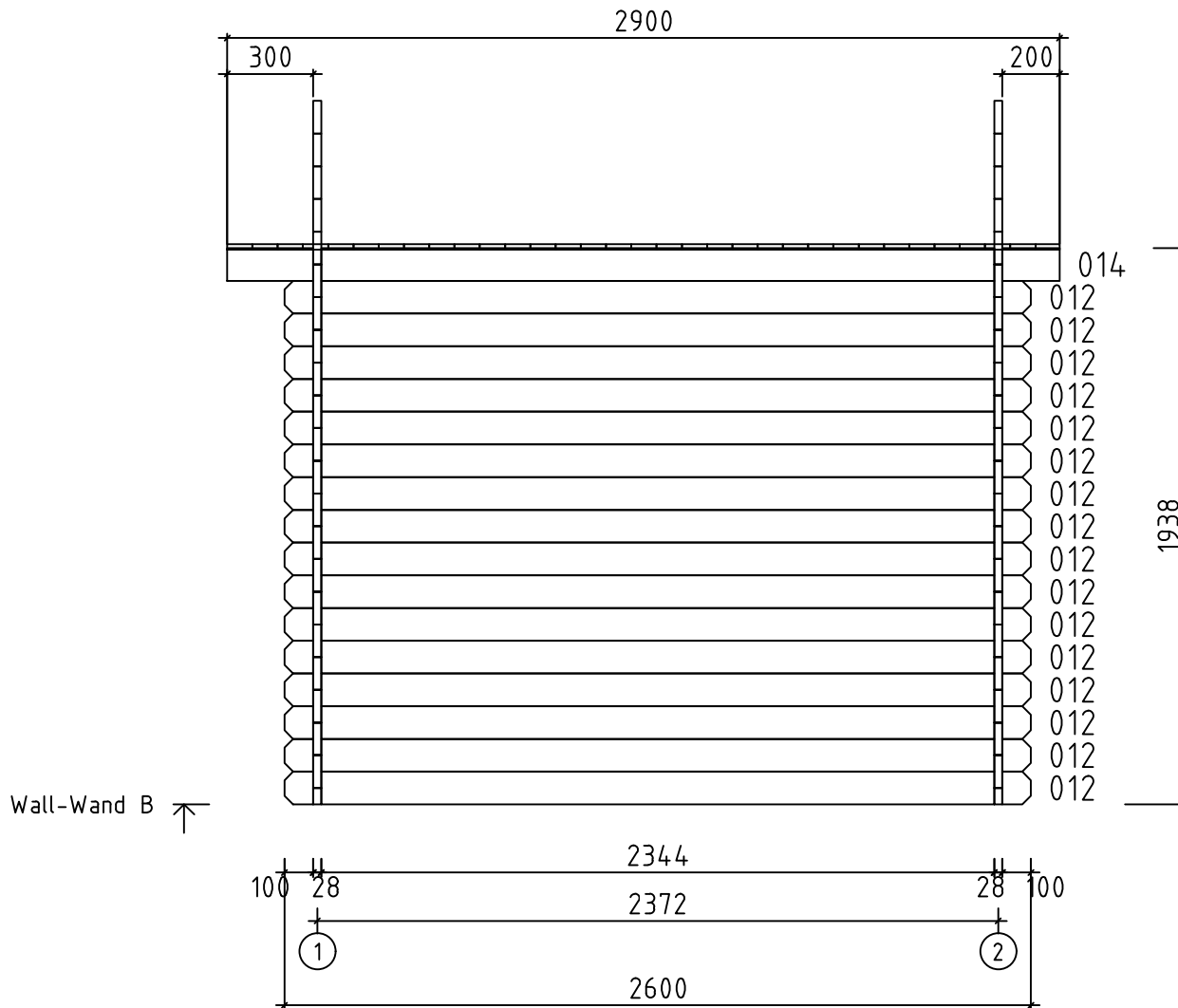

Model	Lars28	Page	3
Client		Scale	1:25
Material	2.8x11.4	Date	10.11.2021
Company		File	Lars28.dwg

Wall-Wand C ↗



Model	Lars28	Page	4
Client		Scale	1:25
Material	2.8x11.4	Date	10.11.2021
Company		File	Lars28.dwg

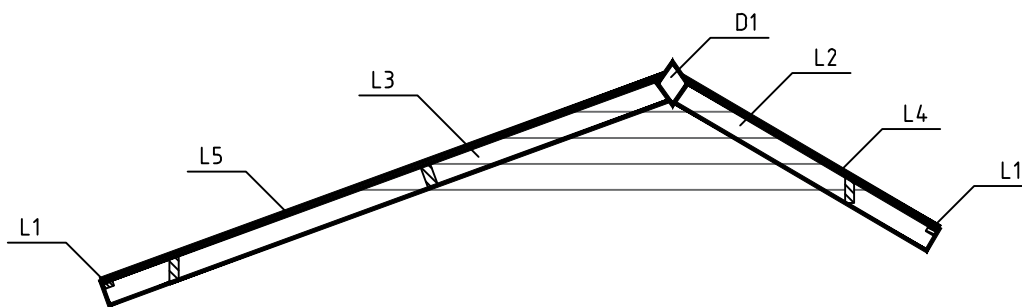
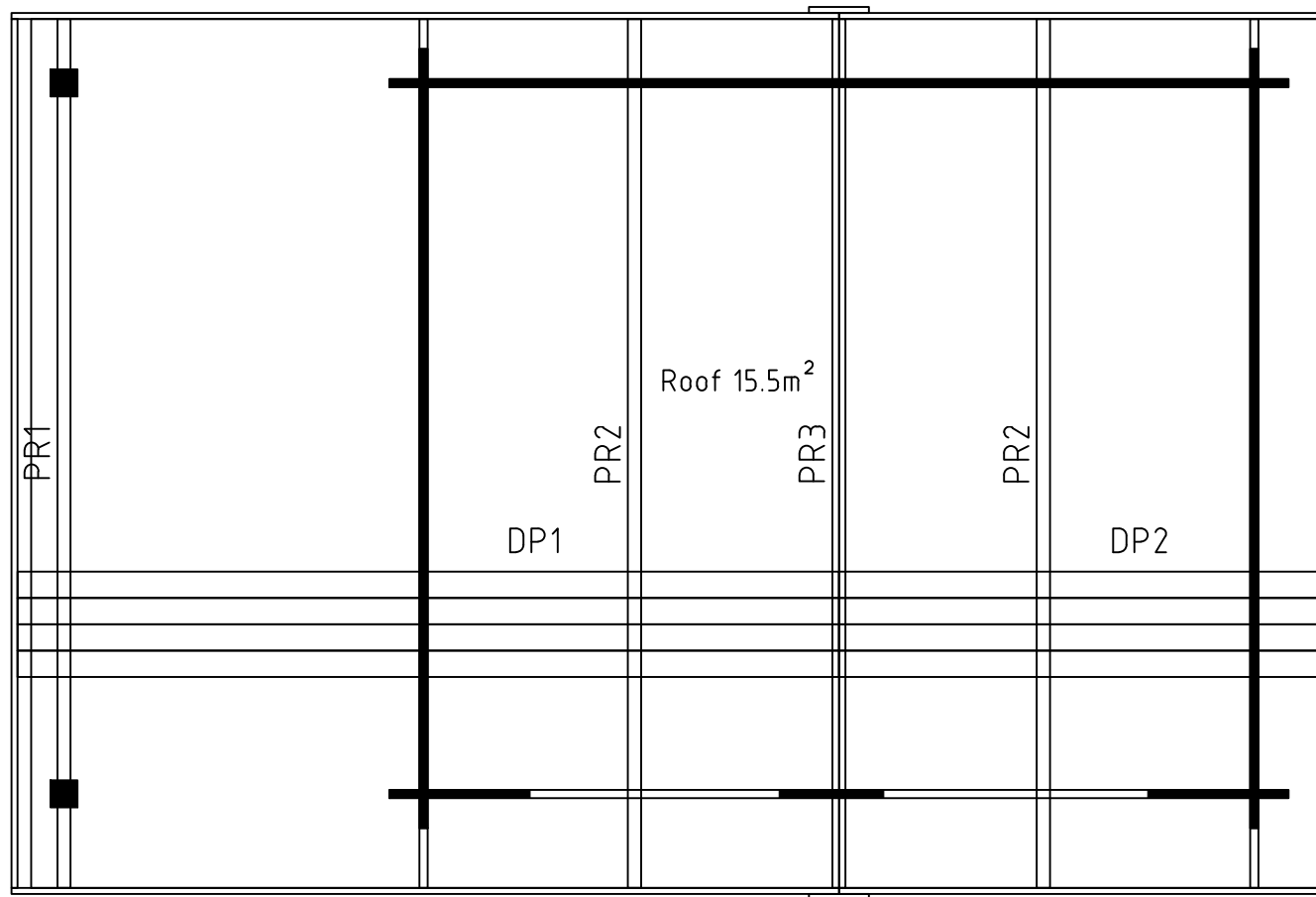

Model	Lars28	Page	
Client		Scale	1:25
Material	28x114	Date	10.11.2021
Company		File	Lars28.dwg

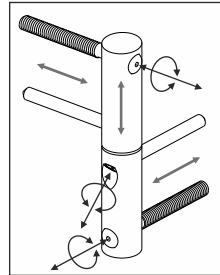
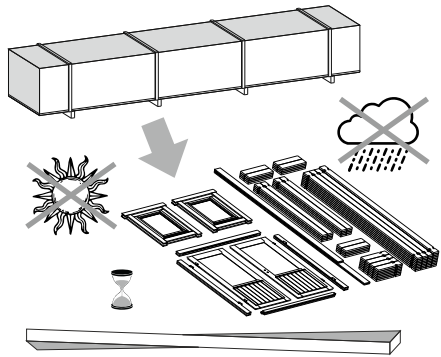
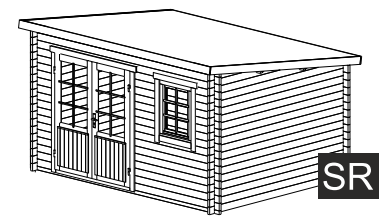
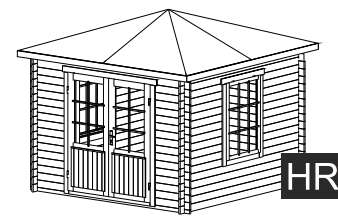
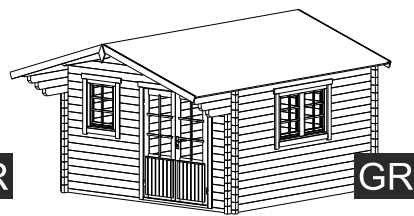
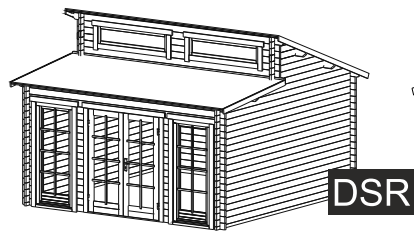
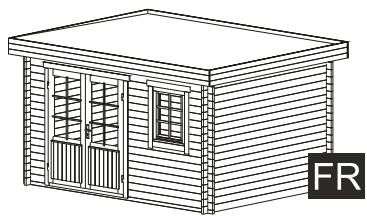

ADJUSTABLE HINGES

3.

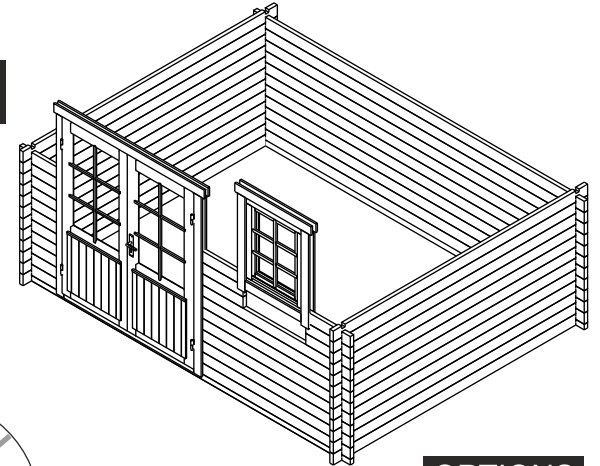

1.

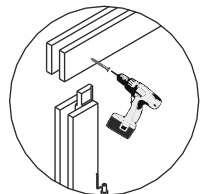
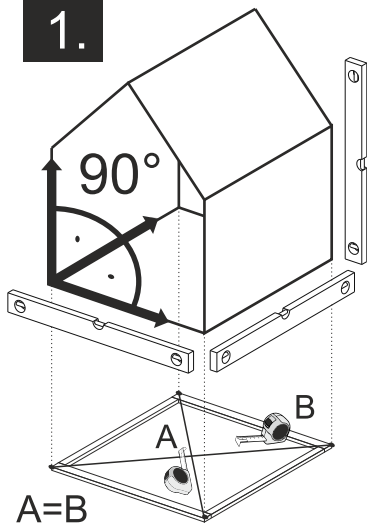

TYPE- B
4x60

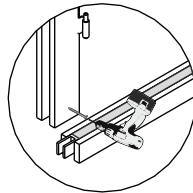

TYPE- A
5x70

2.

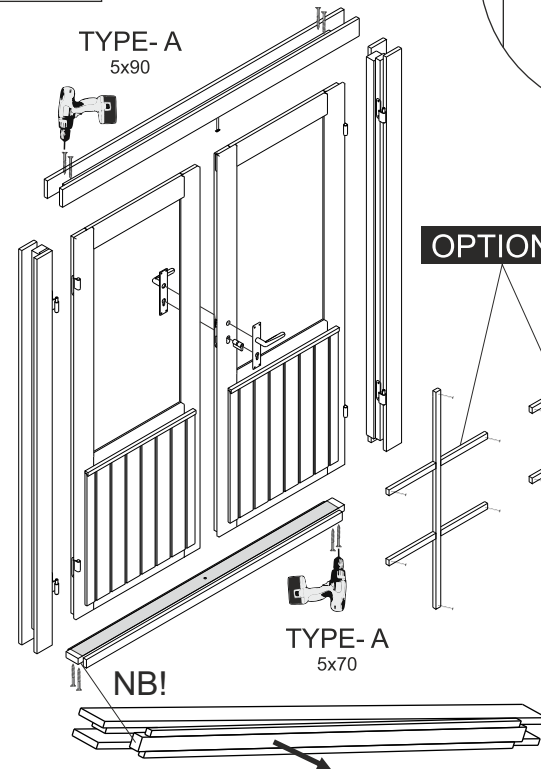

OPTIONS

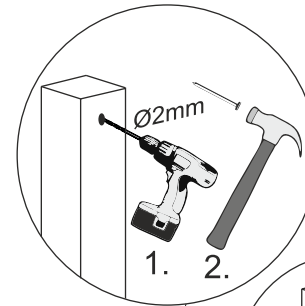

1. 2.

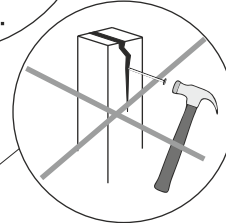

4.

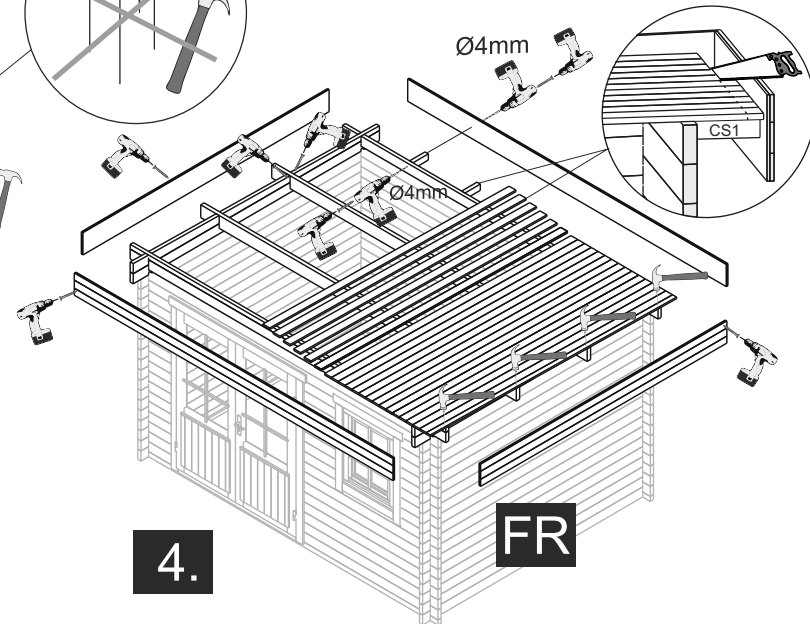

OPTIONS

FR

The guide is illustrative. This guide is not project specification.
Der Leitfaden ist illustrativ. Dieser Leitfaden ist keine Projektspezifikation.
De gids is illustratief. Deze gids is geen projectspecificatie.

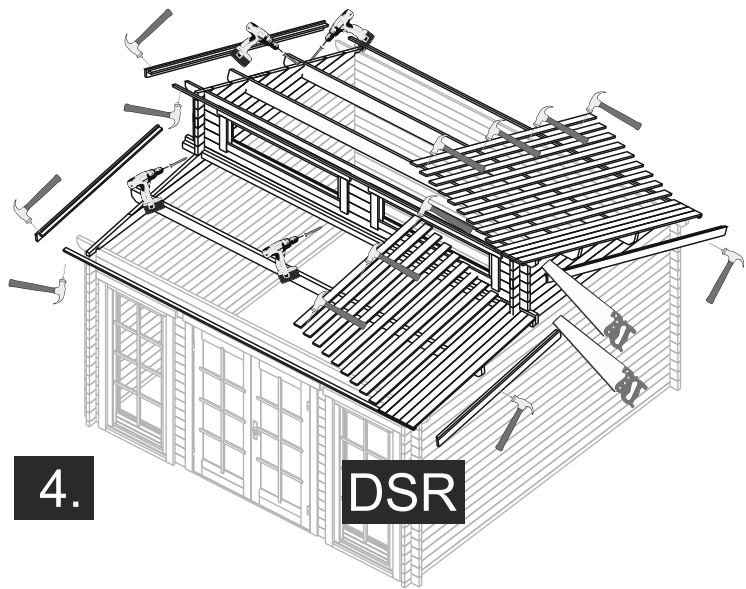

DSR

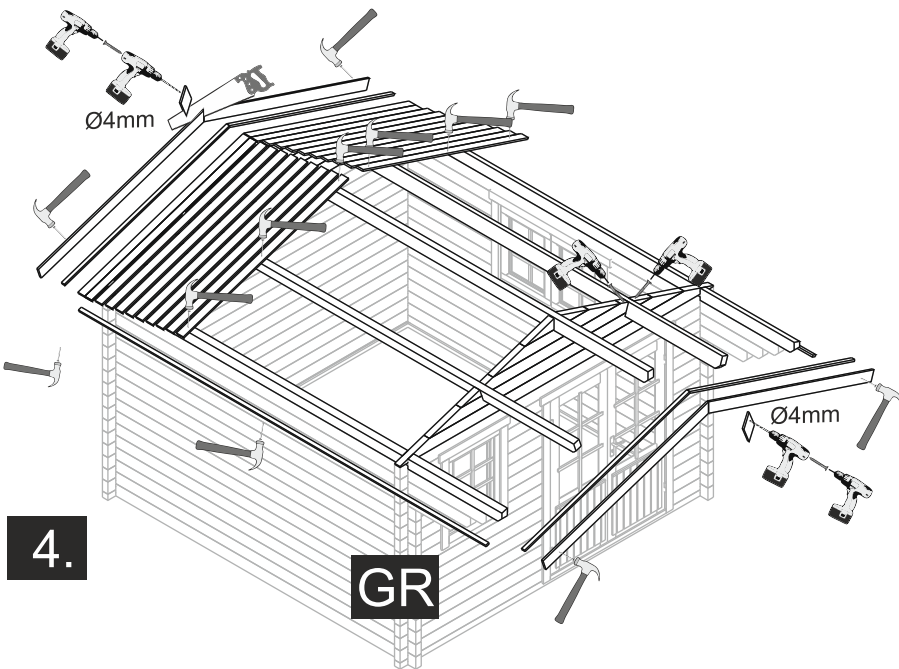

GR

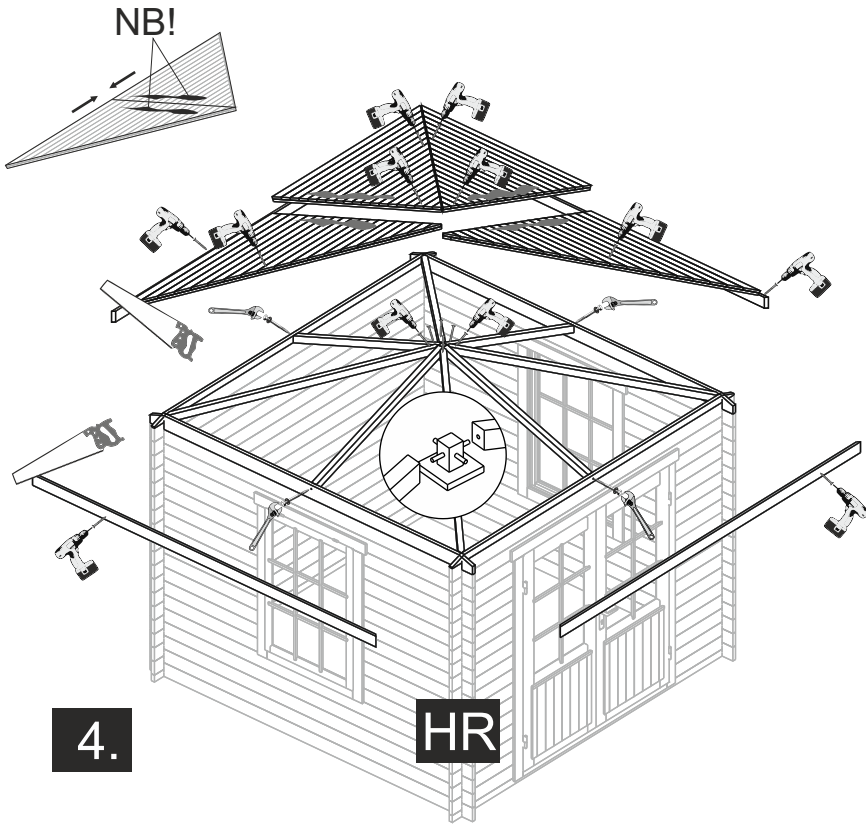

HR

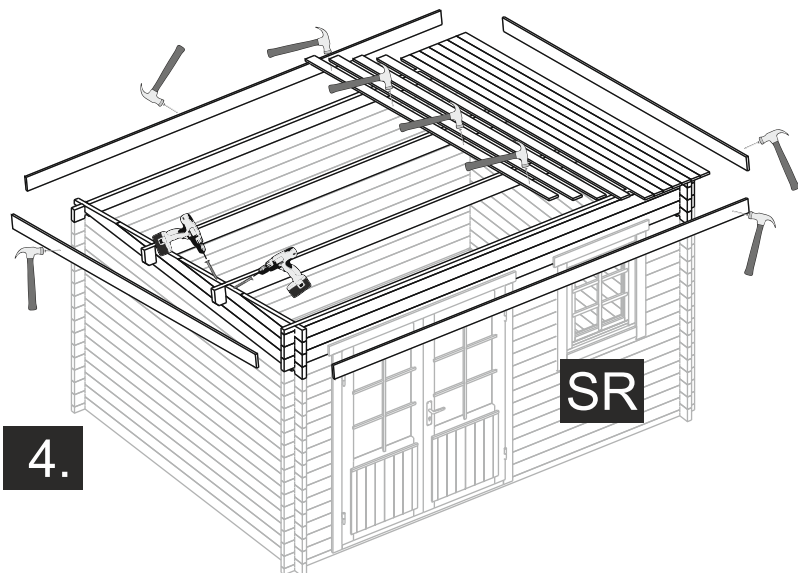

SR

OPTIONS

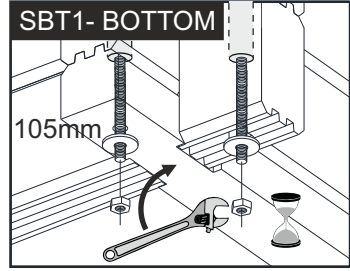
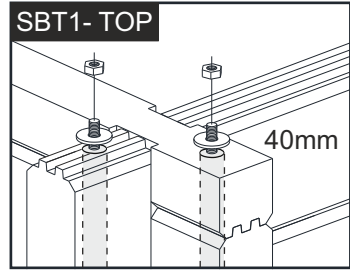
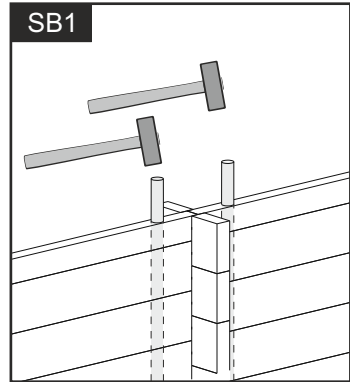

Cutting support post / Schneiden der Stützpfeiler

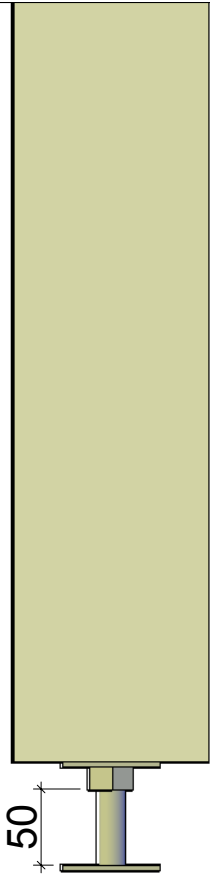

- * Adjustment space for post support should be at least 50mm.
- * Einstellraum für die Pfostenstütze muss mindestens 50mm sein.

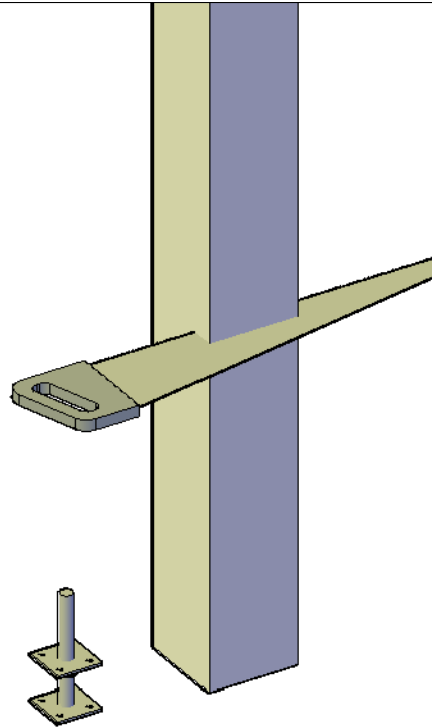

- * Support post has extra length for various conditions. Must be sawn to suitable length on spot considering local conditions.
- * Stützpfeiler hat extra Länge für verschiedene Bedingungen. Muss vor Ort unter Berücksichtigung der örtlichen Gegebenheiten zu einer geeigneten Länge gesägt werden.

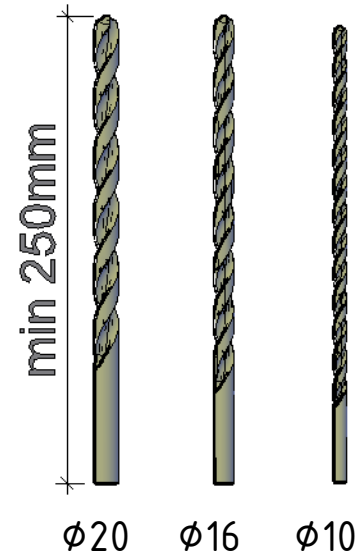
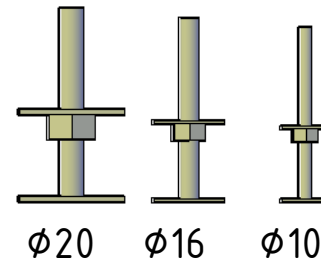

- * In some cases you need to drill a new hole for a post support. Find a matching drill bit.
- * In einigen Fällen müssen Sie ein neues Loch für die Pfostenstütze bohren. Finden Sie hier den passenden Bohrer.

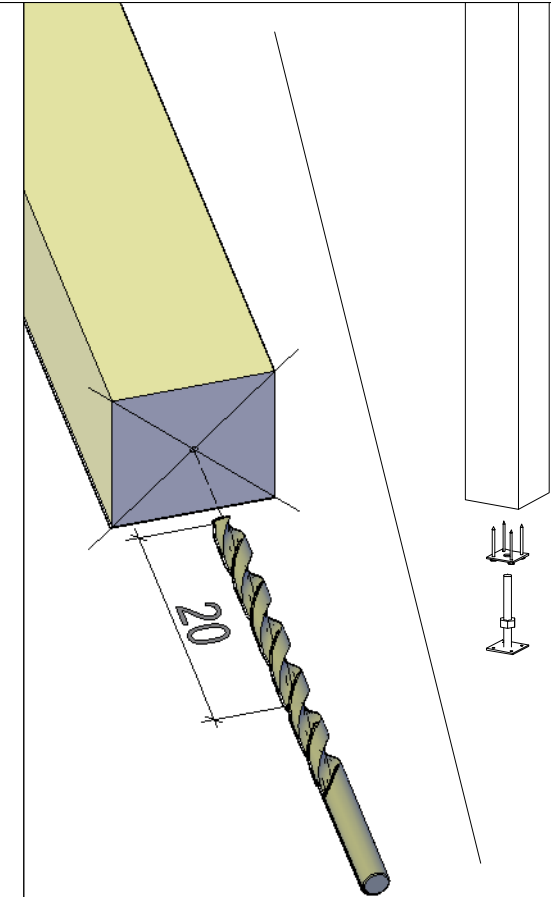

- * Mark the center of the post and drill a new 20cm deep hole. Continue building.
- * Markieren Sie die Mitte des Pfeilers und bohren Sie ein neues 20cm tiefes Loch. Danach mit Aufbau weiter machen.